



Engineered to Deliver

1-800-501-1587

WWW.TRACRAC.COM

IN-27000_E

TRAC ONE

Installation Instructions Manual de Instrucciones Instructions d'installation

TracRac Inc.
994 Jefferson St.
Fall River MA 02721
www.tracrac.com
800-501-1587

Thank you for your purchase of a TracONE™ cargo rack from TracRac®. TracRac® takes great pride in the quality and workmanship we put into every product. We designed the TracONE specifically to meet your cargo management needs and it will do just that. With 800 lbs of load capacity and its heavy-duty aluminum construction you can be sure this rack can handle all of your gear.

To get started, please take a minute to reference the packing list and ensure that all of the components of your TracONE™ are in the package. The installation should take you approximately 60 minutes to 90 minutes.

TABLE OF CONTENTS:

TracONE™ Accessories	Page. 3
Installation Overview	Page. 4
Hardware Contents	Page. 5
Upright Assembly	Page. 6
Cross Bar Assembly	Page. 7
Clamp and Truck Installation	Page. 8-9
Español	Page. 10-11
Français	Page. 12-14
Warranty	Page. 15
Product Registration	Page. 16-17

For further assistance, please don't hesitate to call TracRac's
Technical Assistance Team @ 1-800-501-1587

or

You can view a step by step installation guide on YouTube.com
Search Keyword: T-Rac G2
(www.youtube.com/watch?v=y_57jxcCckw)

PLEASE READ BELOW - IMPORTANT!

WARRANTY REGISTRATION FORM

- Please DO NOT FORGET to fill out your Warranty Registration Form on the back of this installation guide or online at www.tracrac.com. By completing (this form or on [tracrac.com](http://www.tracrac.com)) and returning your PRODUCT REGISTRATION FORM you will receive these important benefits:

WARRANTY CONFIRMATION:

- Your prompt product registration confirms your right to the protection available under terms and conditions of your TracRac warranty.

PRODUCT PROTECTION:

- We will keep the model number and date of purchase of your TracRac product on file to help refer to this information in the event of a product warranty issue.



Please follow these instructions carefully. Ensure that bolts are torqued to the specified rating and ensure that all diagrammed and instructed relative distances for components are met. Failure to do so will waive the warranty.

TracONE™ Accessories

Toyota Tacoma Mount Kit-



Tacoma Mount Kit w/ A Toolbox Mount Kit

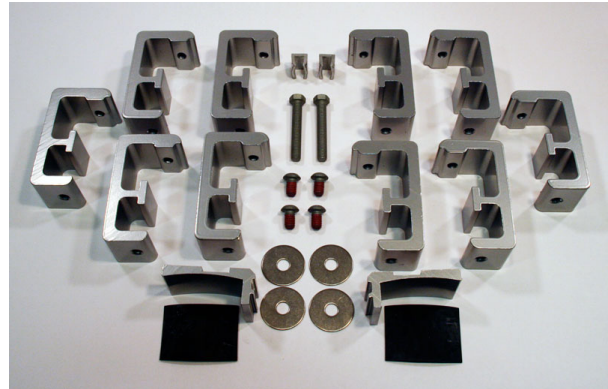

Plastic Loop Tiedowns
 Qty: 4 Tiedowns



Aluminium Die-Cast Tiedowns
 Qty: 2 Tiedowns



Accessory Part Numbers

Part #	Description
25110	Crossbar Tiedowns
44700	Plastic Tiedown Kit (4)
34000	Tacoma Mount Kit (No Toolbox Mount)
41500	Tacoma Mount Kit w/Toolbox Mount
41000	TracONE Toolbox Mount Kit (No Tacoma)

Installation Instructions

Tools you will need:

- 7/32" Allen Key*
- 3/16" Allen Key*
- Tape Measure
- Recommended: Torque Wrench.

*Use a T-Handled Allen Key for better leverage.

7/32" Allen Key*



3/16" Allen Key*



Tools that will make it easy

- 7/32" & 3/16" Hex Bit Socket
- 1/4" Socket Adaptor
- Electric Drill / Socket Wrench

7/32" & 3/16" Hex Bit Socket



1/4" Socket Adaptor

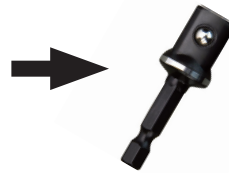

Power Drill

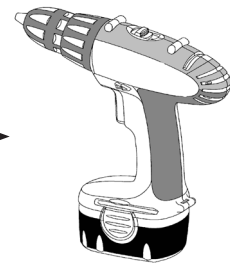

These tools, although not necessary, will make the install time faster.

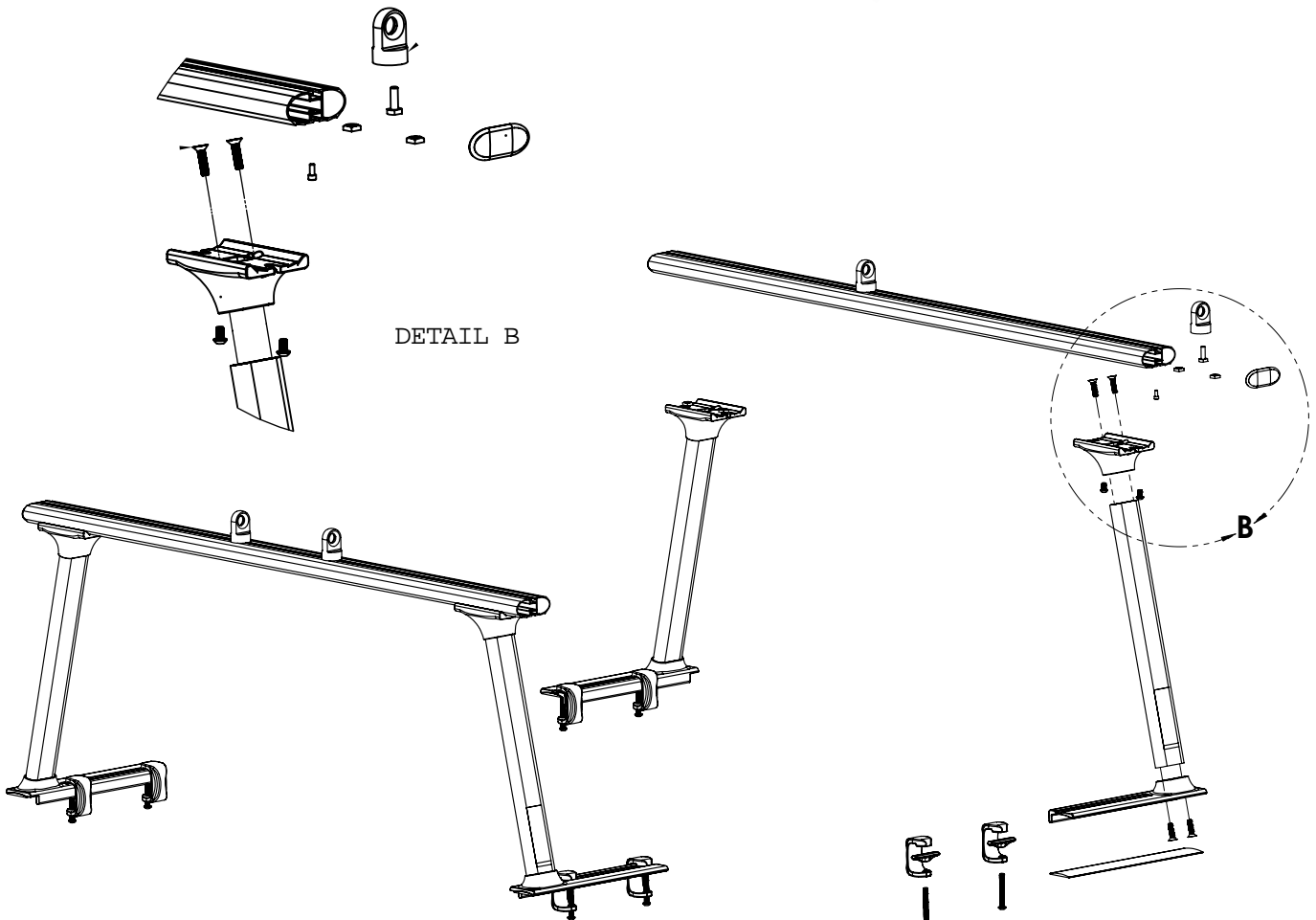

Components & Hardware



Engineered to Deliver

1-800-501-1587
WWW.TRACRAC.COM

ITEM NO.	PART NUMBER	DESCRIPTION	qty
1	01-27021	P/C, DOUBLE T SLOT CROSSBAR	2
2	01-27023	P/C, DOUBLE/TRIPLE CROSSBAR ENDCAP	4
3	01-27012	P/C, MODULAR SADDLE	4
4	01-27006	P/C MODULAR CLAMP	8
5	RX-11034-3	SHIM, ROUNDED	4
6	01-27015	HARDWARE BAG - CLAMPS	1
7	01-27016	HARDWARE BAG - UPRIGHT/SADDLE	1
8	01-27043	HARDWARE BAG - PLASTIC TIEDOWNS	1
9	01-27013	P/C, UPRIGH BASE LF/RR	2
10	01-27035	ASM, MODULAR UPRIGHT	4
11	01-27014	P/C UPRIGHT BASE RF/LR	2

Upright/Saddle Hardware

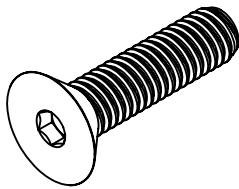

Item # 12
3/8 - 16 x 1.5"
Flat Head Cap Screw
Qty - 16



Item # 13
3/8 - 16 x .625"
Button Head Cap
Screw
Qty - 8

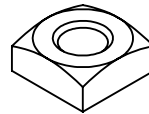

Item # 14
3/8 - 16
Square Nut
Qty - 8

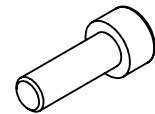

Item # 15
M6-1
Socket Head Cap
Screw
Qty - 4

Clamp Hardware

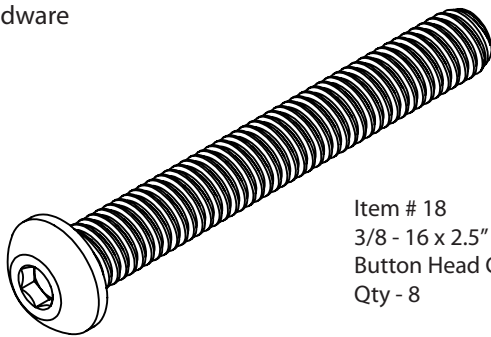

Item # 18
3/8 - 16 x 2.5"
Button Head Cap Screw
Qty - 8

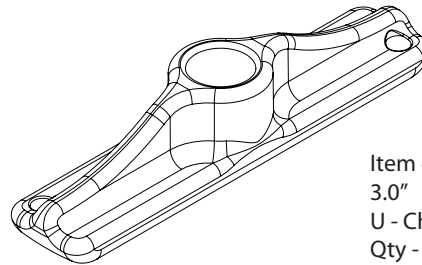

Item # 19
3.0"
U - Channel
Qty - 8

Plastic Tie-down Hardware



Item # 20
Plastic Tiedown
Qty - 4

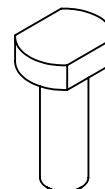

Item # 21
3/8 - 16 x 1.125"
T-Bolt
Qty - 4

Step 1

UPRIGHT ASSEMBLY

1. Insert the top (opposite the decal) of the upright (Item 10) into the Saddle (Item 3). Make sure that the smaller loft is facing the side with the decal. (see image)
2. Bolt the saddle through the top by using two 3/8"-16 FHCS (Item 12) and tighten using a 7/32" Allen Key (or 7/32" Allen Drive Bit). Torque the 3/8"-16 FHCS to 32 ft-lbs.
3. NOTE: We recommend threading both flat head cap screws initially by hand to ensure that you don't cross thread the bolt. The bolt may seem difficult to thread - This is normal and will ensure proper rack performance. When tightening the 3/8" FHCS ensure that the Allen Key is fully seated in the bolt so that it will not strip.
4. Now take the upright and saddle and bolt it to the modular base (Item 11 or 9). When bolting the base to the upright make sure that the decal is facing the larger loft of the base (opposite the L shape-lip of the base)
5. Repeat Steps 1-4 for the remaining three uprights.

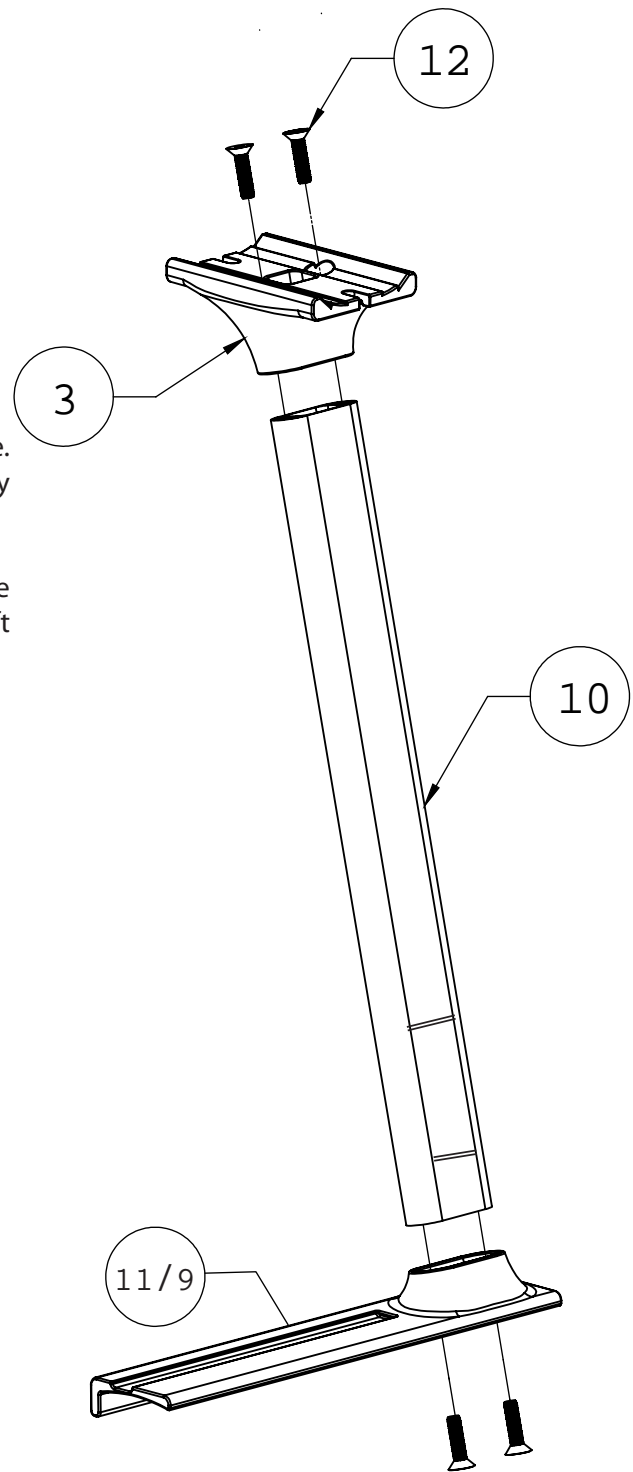
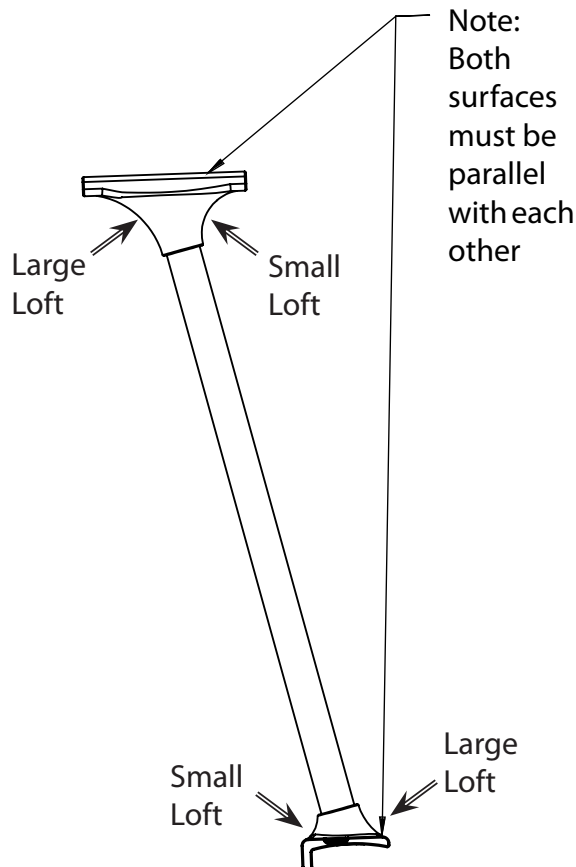

Part 2 - Cross Bars

CROSSBAR ASSEMBLY

1. Pre-thread the all of the Button Head Cap Screw (Item 13) into the flat side of the Square Nuts (Item 14) and set to the side. See Image A
2. Line up the assembled up rights in pairs as they would be placed onto the truck - left and right with the bases facing the same direction.
3. Take 2 of the BHCS/Square Nuts (with the square nuts facing up) place one into each of the slots of the upright saddle. See Image C
4. Take one of the Crossbars (Item 1) and orientate the bar so that the bottom is facing the floor. See Image B. Holding the bolts in the slots of the saddle See Image C, slide the square nuts into the bottom T-Slot of the cross-bar. See Image D
5. Repeat Steps 1-4 with the opposite upright.
6. Repeat Steps 1-5 with the other pair

Image A

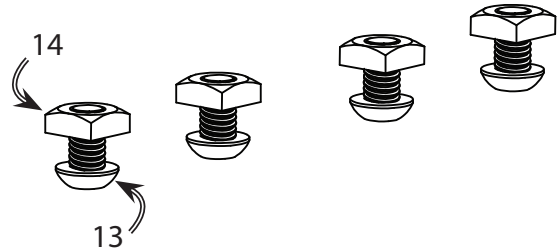

Image B

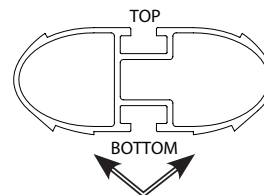

Image C

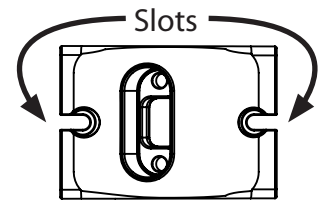
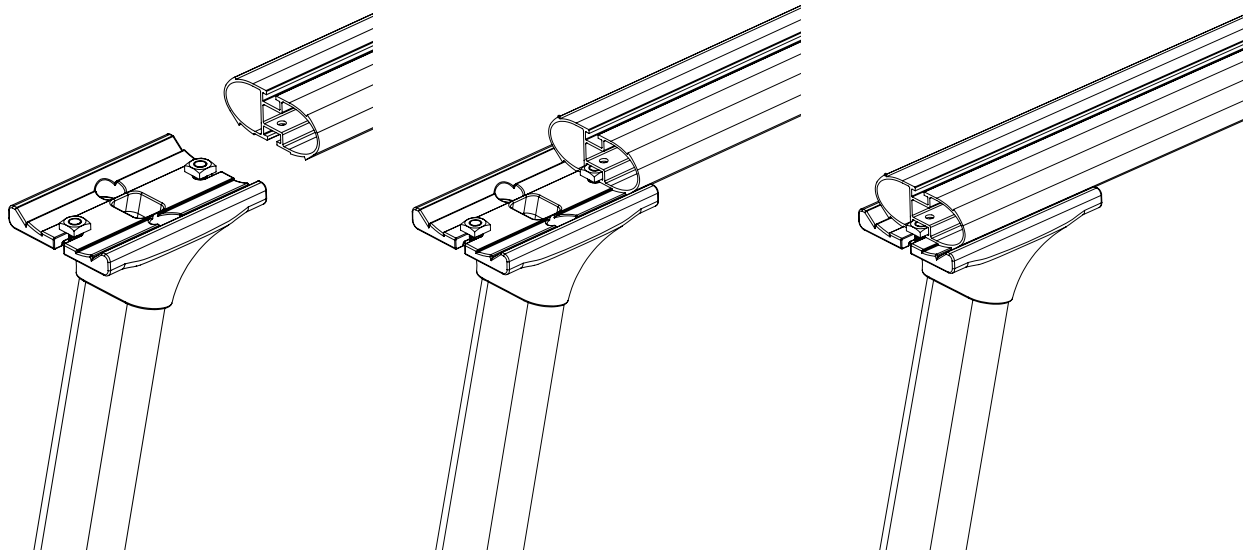

Image D



TIEDOWNS AND END CAPS

1. Remove the plastic crossbar tiedowns (Item 20) and T-bolts (Item 21) from the packaging. Partially thread the T-bolt through the hole in the bottom of the tiedown. See Image A. Slide the unit into the top track of the crossbar and twist the tiedown until securely in place.
2. Next locate the aluminum crossbar end caps (Item 2). Making sure the flat side of the end cap is facing towards the ground, See Image B insert the end cap into the end of the crossbar and secure using the socket head cap screw (Item 15). See Image C.

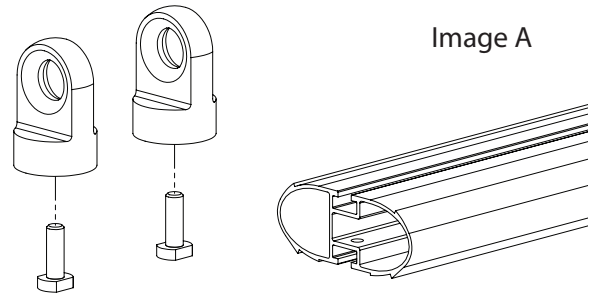

Image A

INSTALL NOTE:

Now you're ready to put the rack onto the truck. If you're alone, we recommend that you place the racks into the truck's bed before placing into position.

INSTALLING THE RACKS

1. Take the rounded shims (Item 5) and place them on the sidewalls of your truck approximately where the uprights will sit.
2. Place the front uprights on top of the rounded shims making sure that the rubber shims are completely under the bases.
3. Place the rear uprights on top of the rounded shims making sure that the rubber shims are completely under the bases.
4. When the racks are in place, adjust the uprights outwards towards the inner lip of the truck bed so that the I-rail of the base is as close to the truck bed as possible.

Note: Due to the taper in many trucks beds, the I-rail on the base may not but completely against the side of the truck bed. This gap is normal and will not affect the performance of the rack.

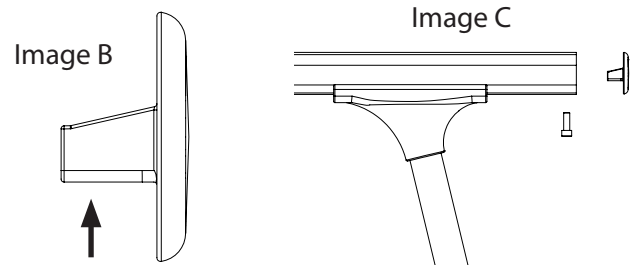
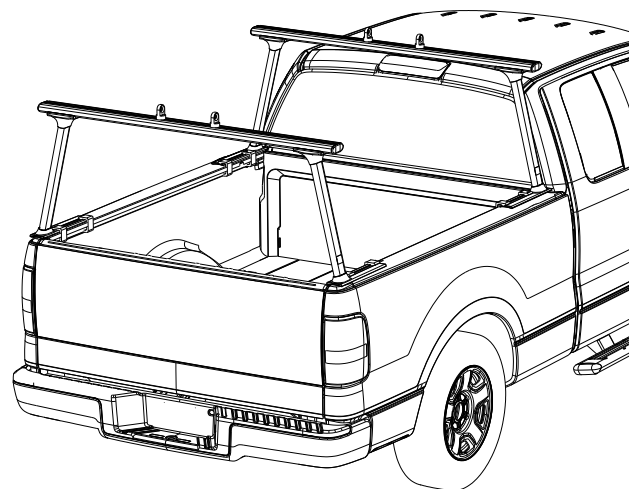

Image B

Image C

Flat side down



Part 4 - Clamps & Truck Installation



Engineered to Deliver

1-800-501-1587

WWW.TRACRAC.COM

CLAMP ASSEMBLY

1. Take a Front Clamp (Item 4) and thread a 3/8"-16 BHCS (Item 18) through the bottom as shown. See Image A
2. Now take a clamp foot (Item 19) and place it on top of the 3/8" BHCS as shown.
2. Repeat steps one and two for the remaining seven clamps.

We recommend that you apply Loc-Tite (red) to any thread that is engaged with the clamp. BHCS (Item 18) should be re-torqued every 5000 miles. ⚠️

Image A

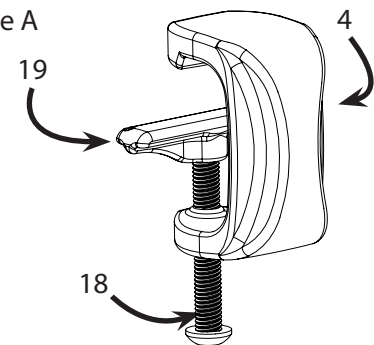

Note: clamp feet must be used to ensure proper tension between the rack and the truck bed and prevent damage

BASE/CLAMP INSTALLATION

1. First you want to ensure that your racks are in proper position and the shims are in place underneath. The Front Base has a notch in the front - THIS NOTCH MUST BE ALL THE WAY TO THE FRONT OF THE CAB SO THAT THE BASE IS ON THE BULKHEAD.
2. Front Rack - Hook 2 clamp assemblies onto either side of the truck bed rail and slide into the groove on the base. Place the front clamp as far forward toward up right as possible and the rear clamp as far back on the base as possible. See Image B. When positioning the clamps make sure they are spaced at least 7 5/16 inches apart. Any less of a distance will reduce the load capacity of the rack. See Image C
3. Torque the clamps on either side of the rack towards the cab, then follow with the other two clamps towards the rear of the truck. Torque down the BHCS to 14 lb-ft
4. Repeat steps 1-4 on the rear rack. The rear uprights should sit as far towards the tailgate as possible without the base hanging off the back of the bed rail, while maximizing the distance between the clamps. NOTE: When positioning the clamps make sure they are spaced at least 7 5/16 inches apart. Any less of a distance will reduce the load capacity of the rack. You may adjust the position of the rear rack on the bed to ensure that this distance can be achieved
5. Finally, with the uprights secured you now want to take a measuring tape and center your crossbars. Once centered use your 7/32" Allen Driver to fully secure your crossbars. Torque the BHCS to 27 ft-lbs.

Image B

NOTE: BE SURE TO KEEP THE RUBBER SHIM UNDER THE BASE WHEN TIGHTENING THE CLAMPS

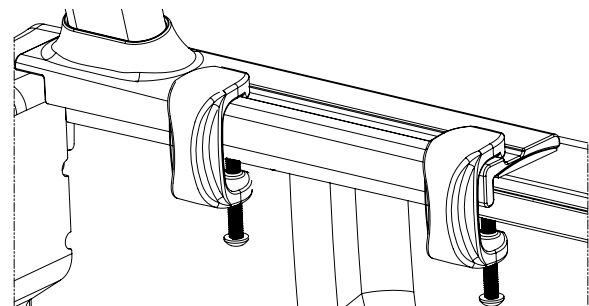

Image C

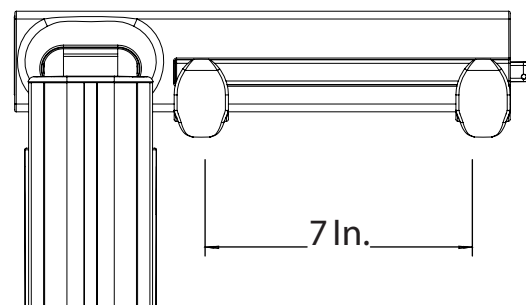
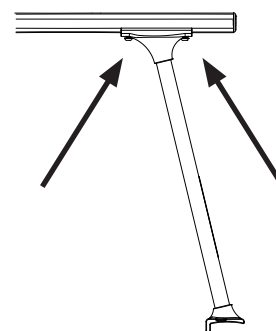

Image D



Paso 1

1.1 Montaje de las barras verticales

1. Primero tome la barra vertical (ítem 4) e insértela en un soporte modular (ítem 3).
2. Atornille el soporte desde la parte superior con dos tornillos de cabeza plana de 3/8"-16 (ítem 12) y ajústelos con la llave Allen de 7/32" (ítem 16) y una llave de tubo con conector de 1/4". Apriete con firmeza los tornillos de cabeza plana de 3/8"- 16 a 32 libras-pie. Recomendamos enroscar los tornillos de cabeza plana primero a mano para asegurarse de que no pase la rosca del perno

⚠ 1.1.1 Cuando ajuste los tornillos de cabeza plana de 3/8", asegúrese de que la llave Allen esté completamente asentada en el perno para que no lo arranque.

3. Ahora tome el conjunto de la barra vertical y soporte, y atorníllelo en la base modular (ítem 5).
4. Atornille la base desde la parte inferior con dos tornillos de cabeza plana de 3/8"-16 (ítem 12) y ajústelos con la llave Allen de 7/32" (ítem 16) y una llave de tubo con conector de 7/32". Apriete con firmeza los tornillos de cabeza plana de 3/8"- 16 a 32 libras-pie.
5. Para la otra barra vertical delantera, repita los pasos uno a cuatro, excepto que debe usar el (ítem 6) en el paso tres.
6. Repita los pasos 1 a 5 para cada una de las barras verticales.

1.1.2 **NOTA:** El ítem 5 y el ítem 6 son imágenes espejo entre sí. Consulte la lista de verificación del empaque para confirmar qué pieza debe usar.

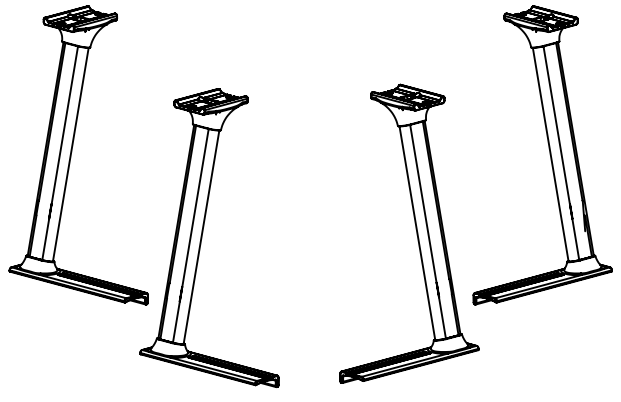
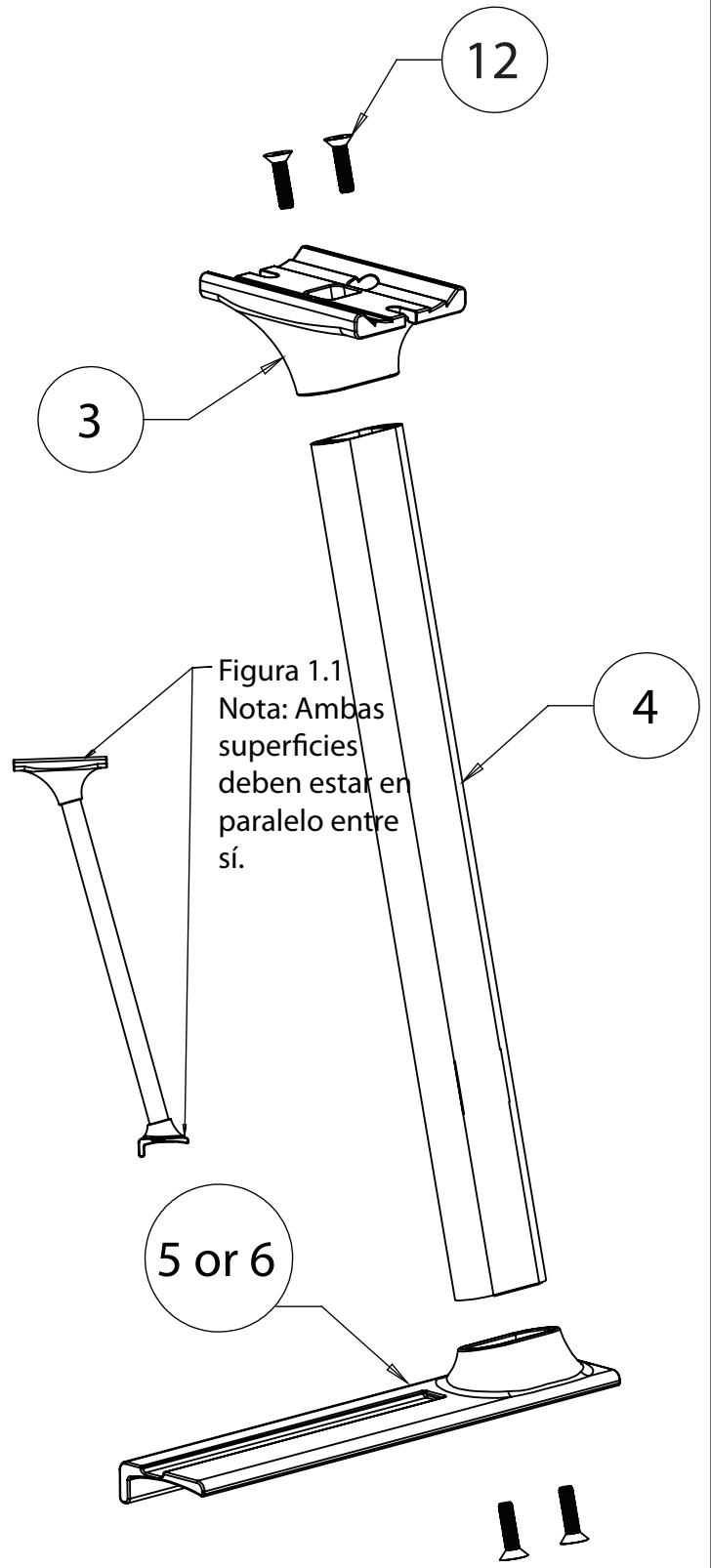

Paso 2

2.1 Montaje de la barra transversal

1. Tome la barra transversal con doble ranura en T (ítem 1) e inserte cuatro tuercas cuadradas (ítem 14) en la ranura en T inferior. Consulte las Figuras 2.1, 2.2 y 2.3.
2. Inserte un perno en T (ítem 21) desde la parte inferior del anclaje de la barra transversal (ítem 20) y deslice la unidad en la guía superior de la barra transversal, para que tanto el perno como el anclaje queden fijados en la guía en T.
3. Inserte la tapa del extremo de la barra transversal con la superficie de montaje plana mirando hacia abajo en el extremo de la barra transversal. Usando el orificio en la parte inferior de la barra transversal y los tornillos de cabeza tubular M6 (ítem 15). Ajuste los tornillos de cabeza tubular M6 usando la llave Allen de 3/16". Repita en el lado opuesto. Consulte la Figura 3.1.
4. Repita los pasos 1 a 4 para la barra transversal restante.



Figura 2.1



Figura 2.2

2.2.1 NOTA: LA CARA PLANA DE LA TUERCA CUADRADA DEBE MIRAR HACIA LA RANURA ABIERTA DEL CANAL

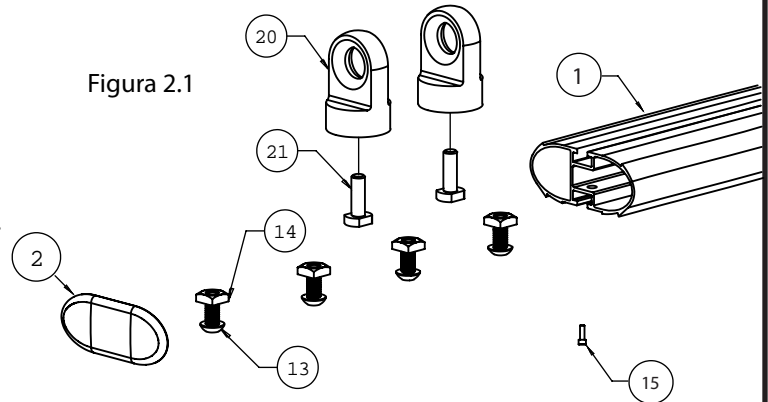

Figura 2.3

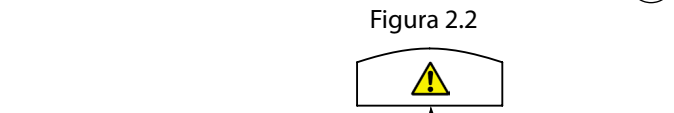
Vista del extremo de la barra transversal

Parte superior

Parte inferior

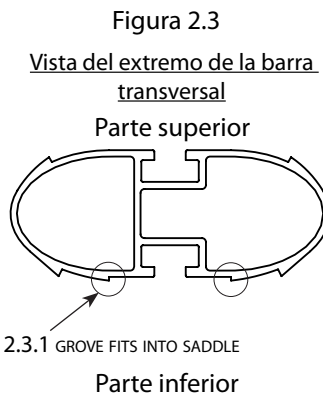
2.3.1 GROVE FITS INTO SADDLE



Figura 2.4

2.4.1 ESTA CARA HACIA ABAJO

Paso 3

3.1. Instalación de la barra transversal delantera y posterior

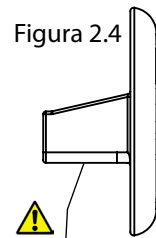
1. Ahora, coloque la barra transversal armada sobre la parte superior de las barras verticales armadas. Verifique que el lado correcto de la barra transversal esté hacia arriba. Consulte la Figura 2.3.
2. Deslice las tuercas cuadradas (ítem 14), para que queden directamente arriba del orificio ranurado en el soporte. Inserte los tornillos de cabeza de botón de 3/8 (ítem 13) dentro de las tuercas cuadradas (ítem 14) y ajuste los tornillos con la llave Allen de 7/32". No apriete por completo los tornillos hasta el paso 8 de la instalación en la camioneta.
3. Repita los pasos 1 y 2 para la barra vertical opuesta.
4. Repita los pasos 1 a 3 para la barra transversal restante.



Figura 3.1

Figura 3.2

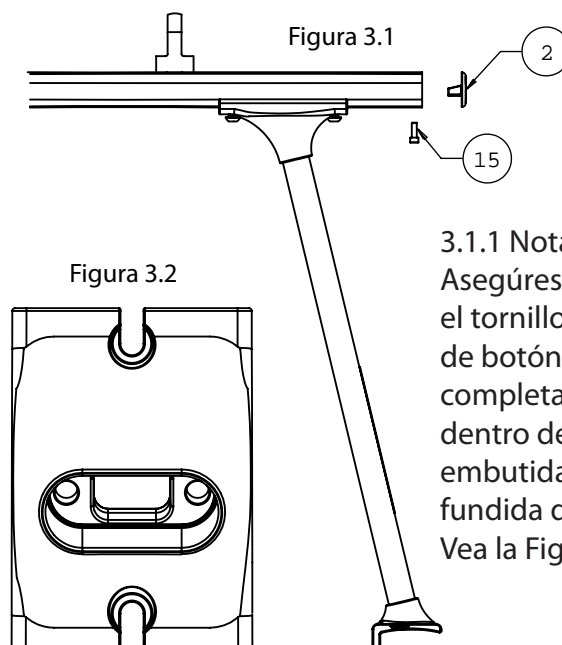
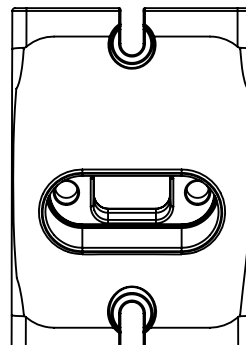

3.1.1 Nota: Asegúrese de que el tornillo de cabeza de botón se asiente completamente dentro del área embutida de la pieza fundida del soporte. Vea la Figura 3.2.

Paso 4

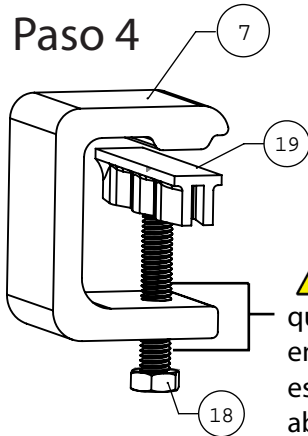

⚠ 4.1.3 Deberá volver a apretar con firmeza los tornillos de cabeza hexagonal (ítem 18) cada 5000 millas.

⚠ 4.1.2 Recomendamos que aplique Loc-Tite (rojo) en todas las roscas que estén engrandas con la abrazadera.

4.1 Montaje de la abrazadera base

1. Tome una abrazadera modular (ítem 7) y enrosque un tornillo de cabeza hexagonal de 3/8" (ítem 18) desde la parte inferior, tal como se indica en la figura. (Consulte la nota sobre el Loc-Tite).
2. Ahora tome un pie de abrazadera de canal en C (ítem 19) y colóquelo arriba del tornillo de cabeza hexagonal de 3/8"; tal como se muestra en la figura.
3. Repita los pasos uno y dos para las siete abrazaderas restantes.

4.1.1 Nota: La base de la abrazadera debe usarse para garantizar la correcta distribución de la fuerza de sujeción entre el rack y la caja de la camioneta, y para evitar daños.

Step 5

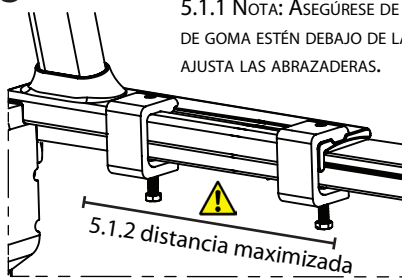

5.1.1 NOTA: ASEGÚRESE DE QUE LAS CUÑAS DE GOMA ESTÉN DEBAJO DE LA BASE CUANDO AJUSTA LAS ABRAZADERAS.

Figura 5.1

5.1 Montaje de la barra vertical delantera y la abrazadera base

1. Ahora tome las cuñas redondeadas (ítem 8) y colóquelas en las paredes laterales de su camioneta, aproximadamente donde quedarán asentadas las barras verticales.
2. Coloque las barras verticales delanteras sobre las cuñas redondeadas (ítem 8), verificando que las cuñas de goma estén completamente debajo de las bases.
3. El par de barras verticales que ahora están en la camioneta deberán ser fijadas usando dos abrazaderas modulares (Paso 4). Cuando ubique las abrazaderas, verifique que estén separadas lo más posible entre sí.
4. Primero, apriete con firmeza las abrazaderas en cualquier lado del rack hacia la cabina, luego continúe con las otras dos abrazaderas hacia la parte trasera de la camioneta.
5. Apriete con firmeza los tornillos de cabeza hexagonal a 14 libras-pie utilizando una llave dinamométrica y una llave de tubo de 9/16".

5.2 Montaje de la barra vertical posterior y la abrazadera base

Las barras verticales posteriores deben asentarse lo más cerca posible de la puerta de descarga sin que la base cuelgue de la parte posterior del riel, y a su vez maximizando la distancia entre las abrazaderas (Figura 5.2).

1. Coloque las barras verticales delanteras sobre las cuñas redondeadas (ítem 8), verificando que las cuñas de goma estén completamente debajo de las bases.
2. El segundo par de barras verticales que están ahora en la camioneta deben ser fijadas con dos abrazaderas (Paso 4) armadas previamente (2 por barra vertical). Cuando ubique las abrazaderas, asegúrese de que estén separadas al menos 7 5/16 pulgadas entre sí. Cualquier distancia menor reducirá la capacidad de carga del rack. Puede ajustar la posición del rack sobre la caja para garantizar que se alcance esta distancia.
3. Repita los Pasos 3 a 5 (5.1) para el rack posterior.
4. Por último, con las barras verticales ya bien fijadas, debe tomar la cinta métrica y centrar las barras transversales. Una vez centradas, use la llave Allen de 7/32" para fijar completamente las barras transversales. Apriete con firmeza los tornillos de cabeza de botón a 27 libras-pie.



Figura 5.2

Français - Instructions d'installation

1ère Partie - Montants

Étape 1

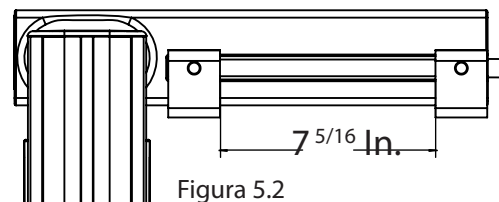
1.1 Upright Assembly

1.1 Assemblage du montant

1. Prenez d'abord le montant (pièce 4) et insérez-le dans un sabot modulaire (pièce 3).
2. Boulonnez le sabot par le haut au moyen de deux vis d'assemblage à tête plate de 3/8 -16 po (pièce 12) et serrez l'ensemble au moyen de la clé Allen de 7/32 po et une douille de 1/4 po. Serrez les 16 FHCS de 3/8 po à 32 pi/lb. Nous recommandons de procéder d'abord au vissage manuel des deux vis d'assemblage à tête plate afin de vous assurer de ne pas fausser le filetage du boulon.

⚠ 1.1.1 Lors du serrage des vis d'assemblage à tête plate de 3/8 po, assurez-vous que la clé Allen est complètement enfoncée dans le boulon afin d'éviter qu'elle ne dérape.

3. Boulonnez l'ensemble montant et sabot dans la base modulaire (pièces 5)
4. Boulonnez la base par le bas au moyen de deux vis d'assemblage à tête plate de 3/8 -16 po (pièce 12) et serrez l'ensemble avec la clé Allen de 7/32 po et avec la clé à douille de 7/32 po. Serrez les 16 FHCS de 3/8 po à 32 pi/lb.
5. Pour l'autre montant avant, répétez les étapes 1 à 4, mais utilisez la pièce 6 à l'étape 3.
6. Répéter les étapes 1 à 5 pour chacun des montants

1.1.2 REMARQUE : Les pièces 5 et 6 sont symétriques. Reportez-vous à la liste de vérification dans l'emballage afin de confirmer la pièce à utiliser.

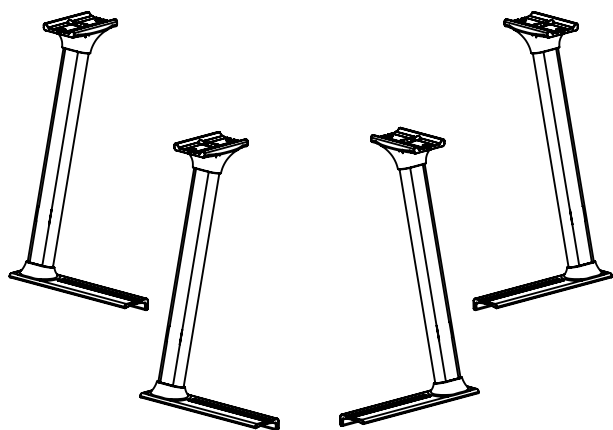
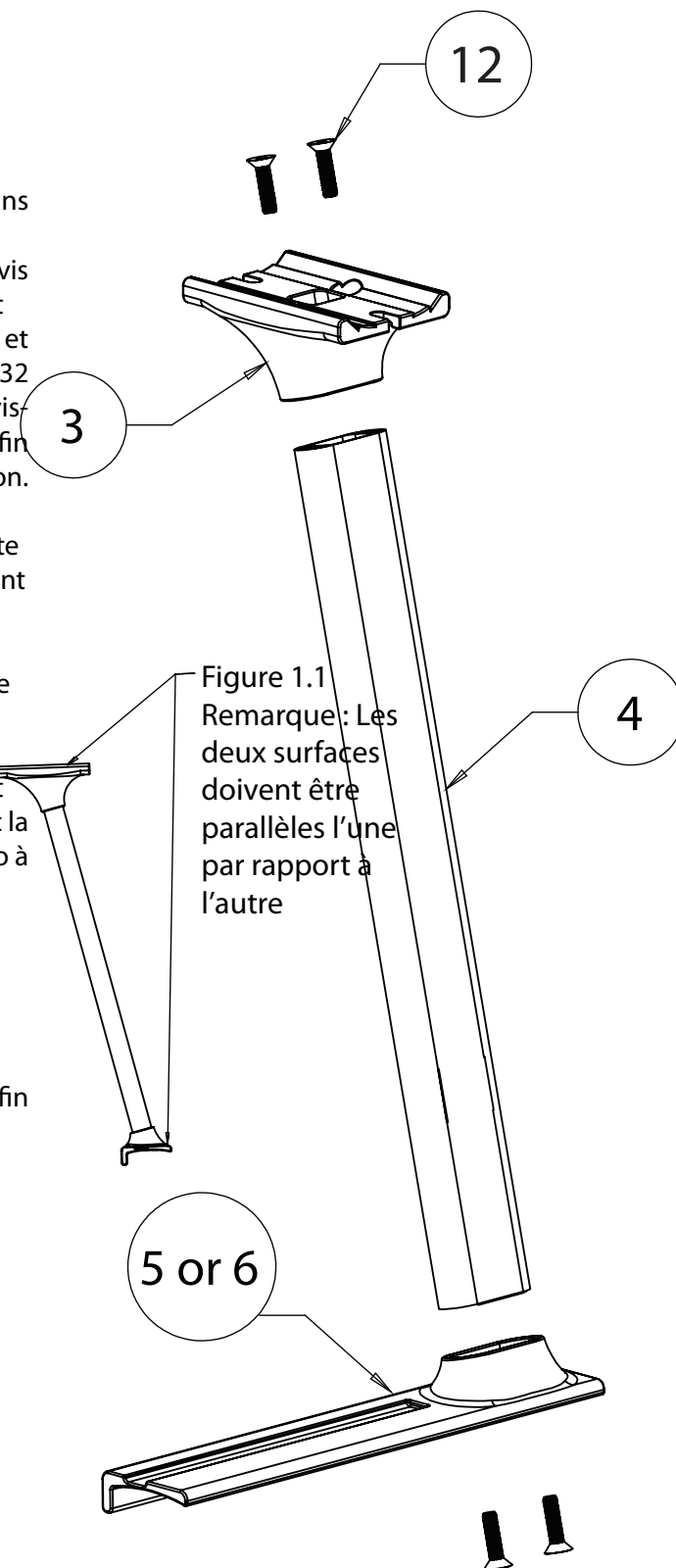

Étape 2

2.1 Assemblage des Barres transversales

1. Prenez la barre transversale à double rainure en T (pièce 1) et insérez quatre écrous carrés (pièce 14) dans la rainure en T inférieure. Reportez-vous aux figures 2.1, 2.2 et 2.3
2. Insérez un boulon en T (pièce 21) à travers la partie inférieure du système de fixation de la barre transversale (pièce 20) et faites glisser l'unité dans la rainure supérieure de la barre transversale pour que le boulon et le système de fixation soient verrouillés dans la rainure en T.
3. Insérez le capuchon d'extrémité de la barre transversale avec la surface de montage plane orienté vers le bas dans l'extrémité de la barre transversale en utilisant le trou de passage en partie inférieure de la barre transversale et le SHCS M6 (pièce 15). Serrez le SHCS M6 en utilisant la clé Allen de 3/16". Répétez l'opération pour le côté opposé. Reportez-vous à la figure 3.1
4. Répétez les étapes 1 à 4 pour les barres transversales restantes.

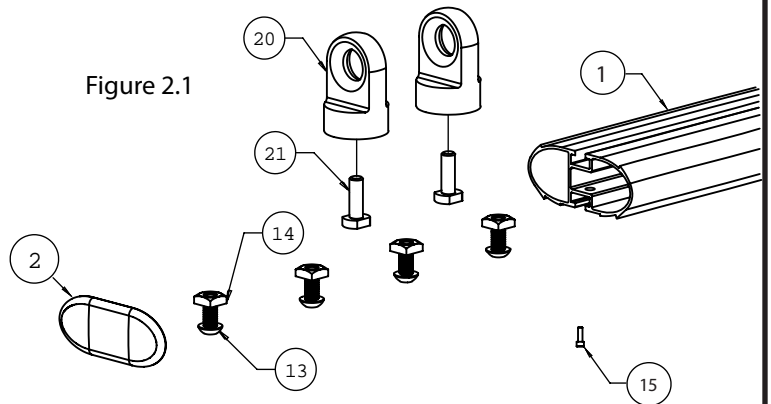

Figure 2.1

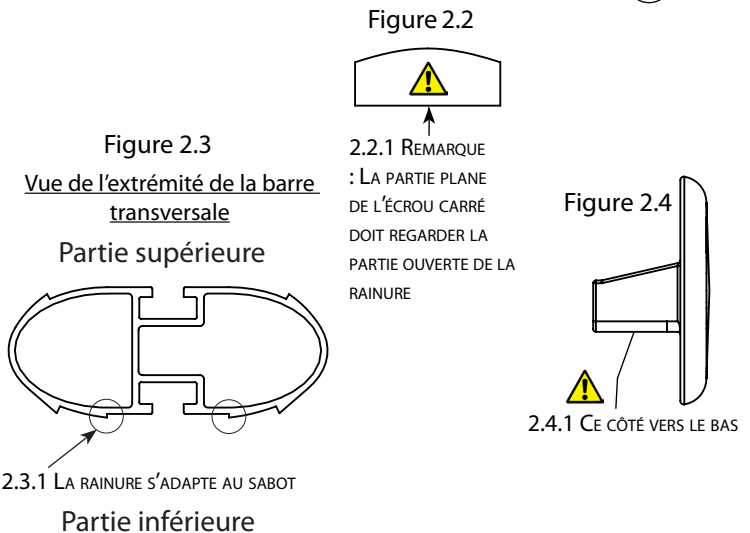

Figure 2.2

2.2.1 REMARQUE : LA PARTIE PLANE DE L'ÉCROU CARRÉ DOIT REGARDER LA PARTIE OUVERTE DE LA RAINURE

Figure 2.4

2.4.1 CE CÔTÉ VERS LE BAS

Étape 3

3.1 Installation des barres transversales avant et arrière

1. Positionnez maintenant la barre transversale sur la partie supérieure des montants assemblés. Assurez-vous du bon positionnement de la barre transversale avec sa face supérieure vers le haut. Reportez-vous à la figure 2.3
2. Faites glisser les écrous carrés (item 14) pour qu'ils se trouvent directement au-dessus du trou ovalisé dans le sabot. Insérez les BHCS de 3/8 po (pièce 13) dans les écrous carrés (pièce 14) et serrez les vis d'assemblage en utilisant la clé Allen comprise de 7/32 po. Ne serrez pas complètement les vis avant l'étape 8 de l'installation sur la camionnette
3. Répétez les étapes 1 et 2 pour le montant opposé.
4. Répétez les étapes 1 à 3 pour les barres transversales restantes.

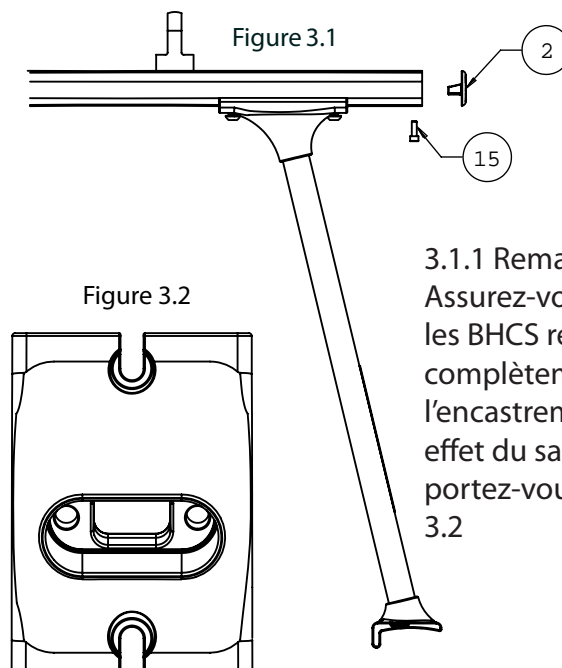
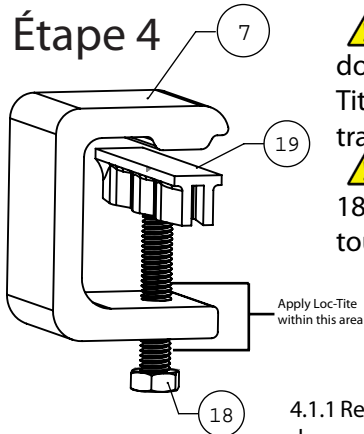

Figure 3.1

Figure 3.2

3.1.1 Remarque : Assurez-vous que les BHCS reposent complètement dans l'encastrement à cet effet du sabot. Reportez-vous à la figure 3.2

Étape 4



- ⚠ 4.1.2 Nous recommandons l'application de Loc-Tite (rouge) sur le filetage traversant l'étrier.
- ⚠ 4.1.3 Les HHCS (pièce 18) doivent être resserrés tous les 5000 miles.

4.1.1 Remarque : Des pattes de serrage doivent être utilisées pour assurer une répartition adéquate des forces de serrage entre le bâti et la plate-forme de la camionnette

4.1 Assemblage des étriers sur la base

1. 1. Prenez un étrier de fixation (pièce 7) et vissez une vis d'assemblage à tête hexagonale 3/8 po -16 (pièce 18) à travers la partie inférieure comme indiqué. (Reportez-vous à la remarque au sujet de la Loc-Tite)
2. 2. Placez une patte de serrage à rainures en C (pièce 19) sur la vis à tête hexagonale de 3/8 po comme indiqué.
3. 3. Répétez les étapes 1 et 2 pour les sept étriers restants.

Étape 5

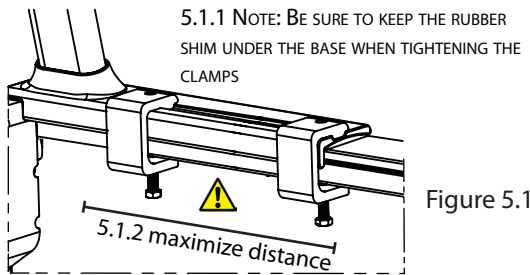

Figure 5.1

5.1 Assemblage des montants avant et des étriers de serrage sur la base

1. Placez maintenant les cales arrondies (pièce 8) sur les parois de votre camionnette approximativement sur l'emplacement où les montants reposeront.

Les montants avant se trouveront directement derrière la fenêtre arrière. Positionnez l'unité aussi loin que possible vers l'avant

2. Positionnez les montants avant sur les cales arrondies (pièce 8) en vous assurant que les cales en caoutchouc sont complètement installées sous les bases.
3. Une paire de montants étant maintenant installés sur la camionnette, ceux-ci doivent être fixés en utilisant les étriers modulaires (étape 4). Lors du positionnement des étriers, assurez-vous qu'ils sont éloignés autant que possible l'un de l'autre.
4. Serrez d'abord les étriers de chaque côté du bâti en direction de la cabine et ensuite les deux autres étriers vers l'arrière de la camionnette.
5. Serrez les HHCS à 14 pi/lb en utilisant une douille de 9/16 po et une clé dynamométrique.

5.2 Assemblage des montants arrière et des étriers de serrage sur la base

Les montants arrière doivent être placés aussi loin que possible du hayon arrière sans que la base ne pende à l'arrière du longeron de plate-forme, tout en maximisant la distance entre les étriers (figure 5.2).

6. Positionnez les montants arrière sur les cales arrondies (pièce 8) en vous assurant que les cales en caoutchouc sont complètement installées sous les bases.
7. La deuxième paire de montants étant maintenant installée sur la camionnette, fixez l'ensemble avec deux étriers précédemment assemblés (étape 4) (2 par montant). Lors du positionnement des étriers, assurez-vous qu'ils sont espacés d'au moins 7 5/16 po. Des distances inférieures réduiront la capacité de charge du bâti. Vous pouvez régler la position du bâti sur la plate-forme afin de vous assurer que cette distance peut être obtenue
8. Répétez les étapes 3 à 5 sur le bâti arrière.
9. Enfin, les montants étant fixés, utilisez un ruban mesureur afin de centrer les barres transversales. Leur centrage étant obtenu, utilisez la clé Allen de 7/32 po afin de fixer complètement les barres transversales. Serrez les BHCS à 27 pi/lb.

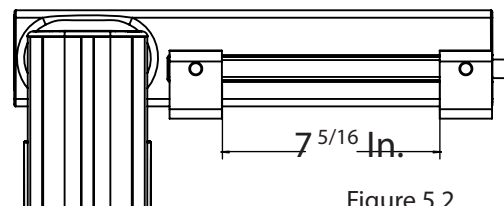

Figure 5.2



TracRac® Limited Lifetime Warranty

TracRac® Limited Lifetime Warranty

TracRac® Incorporated will warranty all TracRac® truck and van racks manufactured by TracRac® Incorporated during the time that an original retail purchaser owns the product. TracRac® will warranty all other accessories for a period of 2 years from the date of purchase. This warranty terminates if a purchaser transfers the product to any other person. To activate this warranty, the original purchaser must complete and return the Product Registration Card included with the product or complete the Warranty Registration on the TracRac® website at <http://www.tracrac.com>, to enable TracRac® to verify original ownership.

Subject to the limitations and exclusions described in this warranty, TracRac® will remedy defects in the structural integrity of the product related to materials or workmanship by repairing or replacing, at its option, a defective product without charge for parts or labor. In addition, TracRac® may elect, at its option, not to repair or replace a defective product but rather to issue to a purchaser a refund equal to the purchase price paid for the product or a credit to be used toward the purchase of a new TracRac® product.

No warranty is given for defects caused by shipping damage, normal wear and tear, cosmetic discoloration, scratches or chips, road hazards, accidents, unlawful vehicle operations, or modification of, or any types of repair of a truck or van rack system other than those authorized by TracRac®.

No warranty is given for defects resulting from conditions beyond TracRac's control including, but not limited to, misuse, overloading, or failure to assemble, install or use the product in accordance with TracRac's written instructions or guidelines included with the product or made available to the purchaser.

No warranty is given for TracRac® products purchased outside of the United States, Canada and Mexico.

In the event that a product is defective, the purchaser should contact the TracRac® Customer Service group in writing or by phone at: 994 Jefferson Street, Fall River, MA 02721 Attn: Customer Service 1 (800) 501 1587

In the event that a product needs to be returned to TracRac®, a TracRac® Customer Service Representative at the address or telephone number listed above will provide the purchaser with the appropriate mailing address and any additional instructions. Please note that the purchaser will be responsible for the cost of mailing the product to TracRac® and that proof of purchase in the form of an original purchase invoice or receipt and a detailed description of the defect must be included in the mailing.

DISCLAIMER OF LIABILITY

Repair or replacement of a defective product or the issuance of a refund or credit (as determined by tracrac) is a purchaser's exclusive remedy under this warranty. Damage to a purchaser's vehicle, cargo and/or to any other person or property is excluded. This warranty is expressly made in lieu of any and all other warranties, express or implied, including the warranties of merchantability and fitness for a particular purpose. Tracrac's sole liability to any purchaser is limited to the remedy set forth above. In no event will tracrac be liable for any lost profits, lost sales, or for any consequential, direct, indirect, incidental, special, exemplary, or punitive damages or for any other damages of any kind or nature. Some states do not allow the exclusion or limitation of incidental or consequential damages, so the above limitations may not be applicable. This warranty gives you specific legal rights, and you may also have other rights, which may vary from state to state.

WARRANTY REGISTRATION FORM

By completing (the form on the next page or on tracrac.com) and returning your PRODUCT REGISTRATION CARD you will receive these important benefits:

WARRANTY CONFIRMATION:

Your prompt product registration confirms your right to the protection available under terms and conditions of your TracRac warranty.

PRODUCT PROTECTION:

We will keep the model number and date of purchase of your TracRac product on file to help refer to this information in the event of a product warranty issue.

WARRANTY REGISTRATION FORM

PERSONAL INFORMATION:

Name(First/Last): _____
Company: _____
Street Address: _____
City: _____
State: _____
Zip: _____
Email: _____

TRUCK INFORMATION:

Make: _____
Model: _____
Year: _____

DATE OF PURCHASE:

MM/DD/YYYY: _____

- What TracRac rack model(s) did you purchase?

TracRac CabRac CapRac
T-Rac G2 TracVan Single Other, please
TracONE TracVan Double specify: _____
ConTractor TracVan Triple

- What TracRac accessories, if any, did you purchase?

TracBox Locking Knobs Kayak Mount
TracBox CO Toolbox Mount Kit Cargo Buckle
Cantilever Base Rail Tie Downs None
Tonneau Cover Cross Bar Tie Downs Other, please specify:
Cargo Divider Bike Mount _____

- What was the total purchase price of the TracRac products you purchased? \$ _____.

- Where did you purchase your TracRac product(s)?

Name: _____
Type of Retailer _____

OVERALL EXPERIENCE SATISFACTION

How satisfied are you with your overall purchase of your TracRac product?

Very Unlikely to Recommend 1 2 3 4 5 6 7 Very Likely to Recommend

How likely would you be to recommend TracRac products to a friend, family member or business associate?

Very Unlikely to Recommend 1 2 3 4 5 6 7 Very Likely to Recommend

LEARNING PROCESS

- What event, if any, triggered the need for you to purchase this TracRac product?

Bought a new truck
Started a new business
Expanded existing business
Bought new sporting equipment (e.g. Kayak, Canoe)
Old rack needed replacement
Just saw it and wanted one

- How did you first learn about this or any other competitive products?

Saw on the road
Talked to sales/store personnel
Looked on the internet
Asked friends or colleagues
Magazine articles or advertisements
Television/Radio shows or advertisements
Store circulars or advertisements

- Where did you go to gather additional information about our products or competitive products? (Check all that apply)

Store
Friends or Colleagues
Product Websites
Internet Forums or Blogs
Other Websites
Company telephone customer support
None

RESEARCH AND USAGE

- What other brands, if any, did you consider before buying your TracRac product(s)? (Check all that apply)

Thule Vanguard
Weather Guard RackIt
System One Pace Edwards
Kargo Master None
Hauler Other, please specify: _____
Cross Tread _____

- What product features most influenced the purchase of your TracRac product(s)? (Check all that apply)

Brand Reputation Quality of Finish
Style/Appearance No Rust Aluminum Material
Load Capacity (How much weight/volume it carries) Reliability/Long Lasting
Load Flexibility (The ability to carry lots of different kinds of loads) Light Weight
Sliding/Easy to Remove Low Wind Noise
Price Quality of Design/Construction
No Drill Mounting Warranty
Other, please specify: _____

- What do you intend to carry with your TracRac product(s)? (Check all that apply)

Lumber Other Sports Equipment (e.g. Surf Boards, Snow Boards, etc...)
Ladders Other Home Building/Improvement Products
Other Home Building/Improvement Products Other, please specify: _____
Kayaks/Small Boats Bikes

PURCHASE AND INSTALLATION SATISFACTION

Please tell us how satisfied you were with the following elements of your initial TracRac Experience:

1. How easy it was to learn about our products?

Very Unlikely to Recommend 1 2 3 4 5 6 7 Very Likely to Recommend

2. How easy it was to choose the right TracRac product for your needs?

Very Unlikely to Recommend 1 2 3 4 5 6 7 Very Likely to Recommend

3. Ability to find a place to purchase our products ?

Very Unlikely to Recommend 1 2 3 4 5 6 7 Very Likely to Recommend

4. How knowledgeable your sales person was about our products?

Very Unlikely to Recommend 1 2 3 4 5 6 7 Very Likely to Recommend

5. How long it took to get your product delivered?

Very Unlikely to Recommend 1 2 3 4 5 6 7 Very Likely to Recommend

6. The quality of the installation (if you paid for installation)

Very Unlikely to Recommend 1 2 3 4 5 6 7 Very Likely to Recommend

7. Length of time to install our product (if you self-installed)

Very Unlikely to Recommend 1 2 3 4 5 6 7 Very Likely to Recommend

8. How well the product fit your truck / How the rack looks on your vehicle?

Very Unlikely to Recommend 1 2 3 4 5 6 7 Very Likely to Recommend

• Please tell us if there is anything we could do better in the future:

• Please tell us if you have any product improvements or suggestions:

DEMOGRAPHIC INFORMATION:

This information will be used in aggregate form only to help us determine how best to provide our target customers with information in the future. This information will never be used or provided to anyone for any other purposes.

- What will you use your truck for?
 Work Only
 Personal Only.
 Work & Personal

• If you selected "Work" as a use for our products please tell us which of the following best describes your type of work. (Circle all the apply)

- | | |
|-------------------------|-------------------------|
| Residential Contracting | Carpentry / Cabinetry |
| Commercial Contracting | Masonry / Concrete |
| Roofing | Construction Management |
| Plumbing | Engineer/Architect |
| Electrical Contracting | Other, please specify |
| Painting | |

• Which of the following activities do you participate in or have an interest in? (Circle all the apply)

- | | |
|------------------------|------------------------------|
| Skiing / Snowboarding | Golf |
| Dirt Bike / ATV Riding | Automotive Repair/Tuning |
| Kayaking / Canoeing | NASCAR / Auto Racing |
| Boating / Sailing | DIY / Home Repair-Remodeling |
| Hunting / Fishing | Gardening |
| Camping / Hiking | Other, please specify |
| Bicycling | |

• Date of Birth: _____

• Education Level

- | | |
|--|--|
| SomeHighSchool..... <input type="checkbox"/> | Graduate Degree (Masters, Doctorate)..... <input type="checkbox"/> |
| HighSchoolGraduate..... <input type="checkbox"/> | |
| CollegeDegree..... <input type="checkbox"/> | |

• Which best describes your family income? (Circle)

- | | |
|-------------------|---------------------|
| Under \$25,000 | \$100,00-\$149,999 |
| \$25,000-\$49,999 | \$150,000-\$199,999 |
| \$50,000-\$74,999 | \$200,000 or over |
| \$75,000-\$99,999 | |

• Would you like us to notify you when TracRac launches new products or has major sales/promotions?

- Yes, please use my mailing address.
 Yes, please use my E-Mail address.....

Email: _____

Please Mail your completed Product Registration Form to :

TracRac Inc.
 Product Registration
 994 Jefferson St. Fall River, MA. 02721

PRODUCTION CODE: